



CS-ID

Vertical Upward Discharge Floor Mounted Induction Unit with Condensate Tray

CS-ID OVERVIEW

The Carson Solutions (CS-ID) floor mounted induction unit comes standard with a vertically mounted hydronic heat exchanger, linear vertical discharge slot, and sloped condensate drip tray. The (CS-ID) induction unit is floor mounted, typically installed along the perimeter wall under the windows and delivers supply air in a vertically upward discharge motion. The (CS-ID) induction unit is designed to be a direct replacement for owners, engineers, and architects looking to replace older, inefficient, legacy-style induction units. CS-IDs can be installed either within existing cabinetry or provided with customized cabinets to provide an updated look. If custom cabinets are part of the renovation scope, Carson Solutions can offer sheetmetal options to enclose and protect the IDU equipment.

CS-ID OVERVIEW (CONTINUED)

The (CS-ID) is offered in two configuration sizes to accommodate typical building design constraints: CS-ID-12 is a shorter/wider model, and the CS-ID-17 is a taller/narrower model. Both (CS-ID) models are engineered to provide high cooling and heating capacities by conditioning the room air while simultaneously supplying fresh conditioned, code required, outside (primary) air to the occupied areas. An integral hydronic coil is designed to supplement the heating or cooling requirements of the space. The central-station Air Handling Unit (AHU) or Dedicated Outdoor Air Supply (DOAS), supplies the induction unit with dehumidified conditioned primary air, providing the required ventilation and humidity control of the space loads. The space sensible loads are addressed with the integrated hydronic heat exchanger inside the induction unit housing. As the primary outside air (OA) pressurizes the plenum of the IDU, the air is forced out a series of induction nozzles. As the primary air exits the nozzles, that process creates a low-pressure area directly behind the hydronic coil, thereby pulling in (inducing) room air through the coil. As the room air passes through the coil, hot or chilled water flow supplementally heats or cools the room air prior to mixing with the OA to satisfy space setpoints. A condensate drip tray is integrally mounted under the hydronic coil for increased condensate protection should it form on the coil surface. An optional factory mounted condensate float switch can be installed for additional condensate management.

The induced room air and the required primary OA mix, and then those combined airstreams are delivered into the occupied zone. This process increases efficiency which maximizes cooling and heating capacity per unit of the mixed air flow streams to deliver premium performance and thermal comfort. The air delivery process from the induction unit has inherent characteristics related to temperature, velocity, and airflow throw to comfortably satisfy occupants.

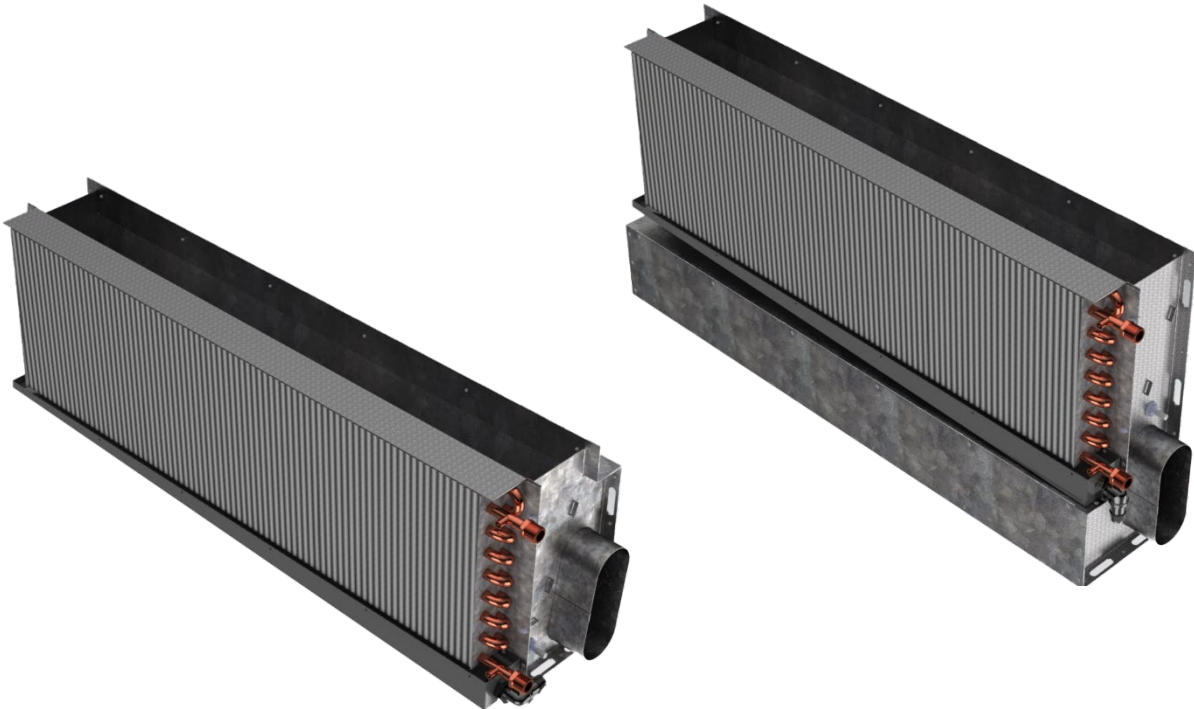

CS-ID OVERVIEW (CONTINUED)

Induction unit technology has been proven to reduce energy consumption and operating cost associated with removal of space sensible thermal loads while simultaneously supplying fresh conditioned air to the occupied area to maintain the proper indoor air quality (IAQ). By handling the sensible load within the space, induction unit technology has been proven to reduce energy consumption and operating cost associated with removal of space sensible thermal loads while simultaneously supplying fresh conditioned air to the occupied area to maintain the proper indoor air quality (IAQ). By handling the sensible load within the space, induction unit technology provides a way to decrease the volume of supply air required to the minimum ventilation rate. Further cost savings are recognized by the reduction in the size and capacity of the AHU or DOAS equipment, smaller ductwork, and other building construction materials. Installation and equipment costs are also commonly reduced in induction unit applications due to reduced code required primary air volume needed to operate each induction unit. Although this equipment is typically applied in renovation projects, it's equally suitable for new construction projects.

CS-ID INDOOR AIR QUALITY & SYSTEM EFFICIENCY

Induction Unit Benefits:

- ❖ Acoustics
- ❖ Thermal Comfort
- ❖ Maintenance
- ❖ Improved Indoor Air Quality (IAQ)
- ❖ Improved Energy Efficiency

Increased awareness of IAQ is prevalent with how it directly affects the presence of airborne contaminants. ASHRAE 62.1 outlines the industry standards for ventilation and acceptable indoor air quality. By applying a DOAS based air handler, the design team can ensure a quantifiable amount of OA is delivered to the occupied spaces. Then utilizing the induction units code prescribed OA can be distributed to the spaces for proper fresh air ventilation.

Additionally, increased system efficiencies can be recognized by the integration of this DOAS/induction unit system approach. Proper sizing of the DOAS unit to handle the latent loads of the ventilation air and the occupants, truly decouples the moisture loads from the temperature or sensible loads of the space, thereby making the system more efficient, as the induction units only need to be sized for the sensible load.

The predominant efficiencies of an induction unit system reside in the fact that induction units are a hydronic method of treating the room's space versus an "all-air" method. Compared to air, water is denser and a more efficient medium for addressing space loads.

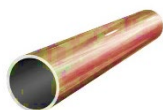

1" Diameter Water Pipe



18"x18" Air Duct

CS-ID INDOOR AIR QUALITY & SYSTEM EFFICIENCY (CONTINUED)

Additionally, the energy required to move water via pump is up to seven times more efficient than fan power to move air.

National and local energy codes are ever evolving and placing more stringent requirements for higher operating efficiencies. ASHRAE 90.1 outlines the energy standard for most commercial building types and local codes should be reviewed carefully. The integration of DOAS/induction units into designs can help engineers deliver proven efficiencies and reduce utility bills for the owners.

CS-ID DECARBONIZATION/ ELECTRIFICATION

An increasing trend in HVAC mechanical designs is the national and local presence of decarbonization or electrification into component selection. By selecting an appropriately designed DOAS unit together with a geothermal or electric based hydronic cooling and heating plant, the designers can check the electrification box for their needs. When using the induction unit as a terminal device, it is a perfect complement to this electrified system design.



CS-ID THERMAL COMFORT

With the Carson Solutions (CS-ID) induction unit offering, occupants will notice an overall increase in thermal comfort in comparison to other traditional HVAC systems. This is due to the induction unit's inherent design characteristics which results in decreasing sound, draft conditions, and temperature irregularities. Induction units are typically operated with sound levels ranging from 20-40. Induction units deliver air at lower velocity than standard overhead systems which reduces cold/hot draft conditions. This also results in efficient and effective mixing of room air and required primary OA which creates comfortable and consistent room temperatures. Temperature control of each space is delivered by its own dedicated room thermostat. Occupant comfort should be a primary concern when evaluating airflow and air distribution requirements. The guidelines in ASHRAE Standard 55 must be followed as it relates to temperatures and velocities within the occupied zone that have a direct impact on occupant comfort. During unoccupied modes, the induction unit coil can act as a static radiator to save energy and enhance thermal comfort by circulating the hot water source and shutting down the air distribution system.



CS-ID DESIGN FEATURES

The Carson Solutions (CS-ID) is supplied with a vertical upward discharge air throw pattern to provide optimal thermal comfort. The (CS-ID) galvanized plenum construction is made using the latest state of the art CNC laser, punching, and forming manufacturing technologies to ensure the highest level of precision throughout the manufacturing process. Currently available are two types of heat exchange coils, a two-pipe system for cooling or heating using a changeover valve and a four-pipe system which enables any room to be cooled or heated independently. Both two and four-piped coils are manufactured as a single or dual circuit arrangement. The (CS-ID) induction unit can also be selected with four nozzle configurations depending on induction ratios needed to meet space load requirements. Three variable inlet sizes are selectable based upon optional induction unit lengths from 2-6ft at 1ft increments. The sloped condensate drip tray features welded corners, powdercoated for corrosion protection, and mounted under the hydronic heat exchanger. The condensate drip trays come standard with a ½" drain connection and is capped from the factory. Optional factory mounted condensate float switch can be installed for additional protection. Water entering the heat exchange coils should be maintained at or above the dew point temperature of the space to mitigate condensation formation. The condensation drip trays should be viewed as safety feature for when conditions fall outside of the design parameters.

CS-ID-12 KEY FEATURES

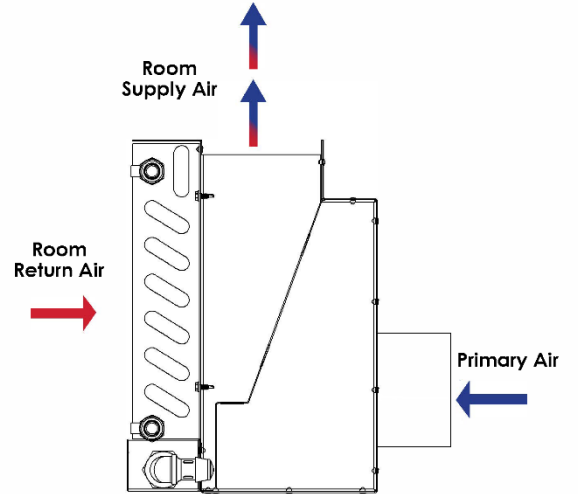
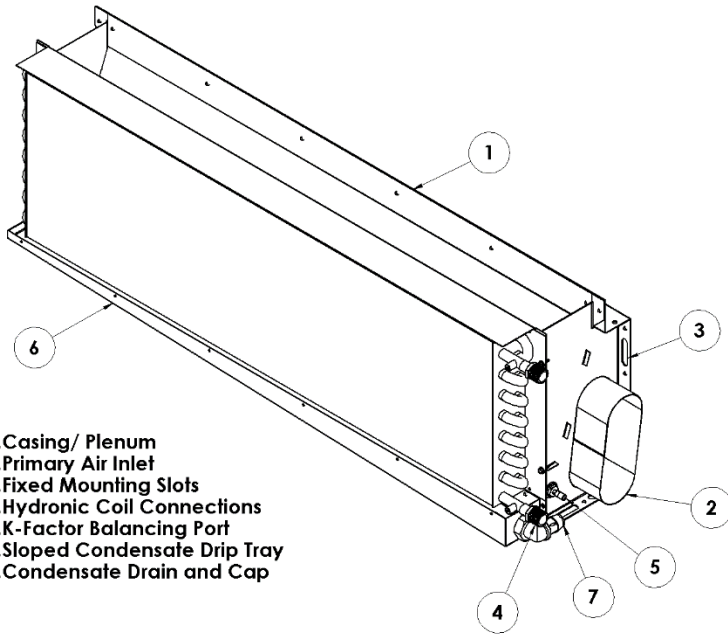

CS-ID-17 KEY FEATURES

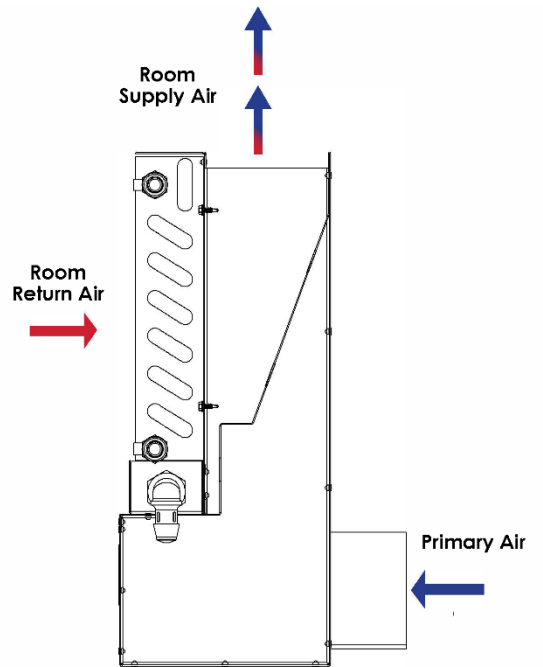
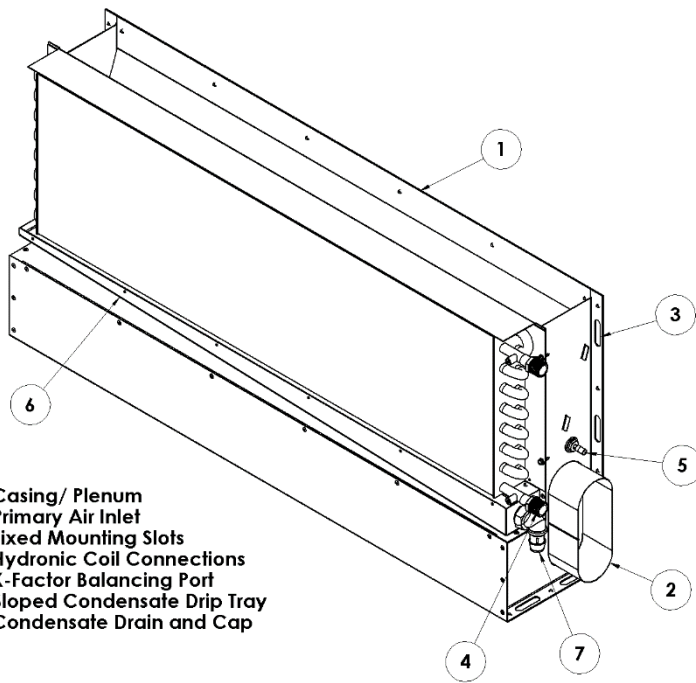

CS-ID PERFORMANCE CHARACTERISTICS

Due to the energy density of water compared to air, on average it takes about 1/10 the energy to move the same amount of thermal energy with hydronic transfer than it does with air transfer through ductwork. Induction units achieve a higher level of mixed air distribution within the room space. Additionally, when the primary air is kept to a minimum, induction units inherit designs offer quiet operation and a higher level of occupant thermal comfort. Primary airflow supply ranges from 10-25 cfm/ft. that delivers 400-1,300 btuh/ft. of induction unit total sensible capacity. The resulting sound levels are determined based upon the selected induction ratio and the induction unit's available primary air inlet sizes to deliver low NC acoustic levels.

Performance Range	Total Sensible Cooling (Btu/h/f)	Total Sensible Heating (Btu/h/f)	Sound Pressure Level NC
CS-ID Vertical Discharge	400 - 1,200	500 – 1,300	20-40

Design Features	Standard Capacity (Vertical Upward Discharge)
Primary Airflow	10 to 25 cfm/ft
Cooling Capacity	Up to 12,000 Btu/h
Heating Capacity	Up to 10,000 Btu/h
Cooling Room Air Temp	73° - 77°F
Heating Room Air Temp	68° - 72°F
Primary Supply Air Temp	55° - 66°F
EWT Cooling	1-2°F Over Space Dew Point
EWT Heating	140 – 200°F
Water ΔT Cooling	2 – 6°F
Water ΔT Heating	9 – 18°F
Water Flow Rate	min: 0.25 gpm max: 2.4 gpm
Water ΔP	0 – 10 ft
Air ΔP	0.2 – 0.8 in



CS-ID APPLICATIONS

The Carson Solutions (CS-ID) is a suitable terminal device solution in a wide variety of applications such as: office buildings, K-12 and Higher Education environments, and varying laboratory spaces. Office building applications are typically installed in open office areas, private offices, conference rooms and hallways which can be utilized in both interior and perimeter zones. For schools and universities, active induction units can be applied in multiple spaces including libraries, classrooms, offices, lecture halls, and labs. In laboratory applications, induction units are typically applied in load driven environments. Healthcare facilities commonly apply induction units in patient rooms and administrative areas.

CS-ID OPERATION AND MAINTENANCE

The Carson Solutions induction unit operation and maintenance is minimal because the supply air is supplied by fans upstream thereby eliminating the need for any electrical connections for each induction unit. Within the induction unit there are no moving parts that need to be maintained, reducing the need for replacement parts. Typically, all the maintenance required for the induction unit itself is “as needed (typically once a year)” vacuuming of the coil, which can be accessed through the ceiling cavity. This also helps keep the service costs to a minimum because all the air filtration occurs upstream within the DOAS unit rather than having to replace individual filters for each induction unit. Proper water treatment should be addressed to prevent corrosion within the hydronic water coil. The induction unit hydronic coil can be drained with the supplied drain valve in case of an issue within the space. If needed, the condensation drip tray can be flushed to remove debris.

CS-ID-12 DIMENSIONAL DATA

Side Inlet Locations

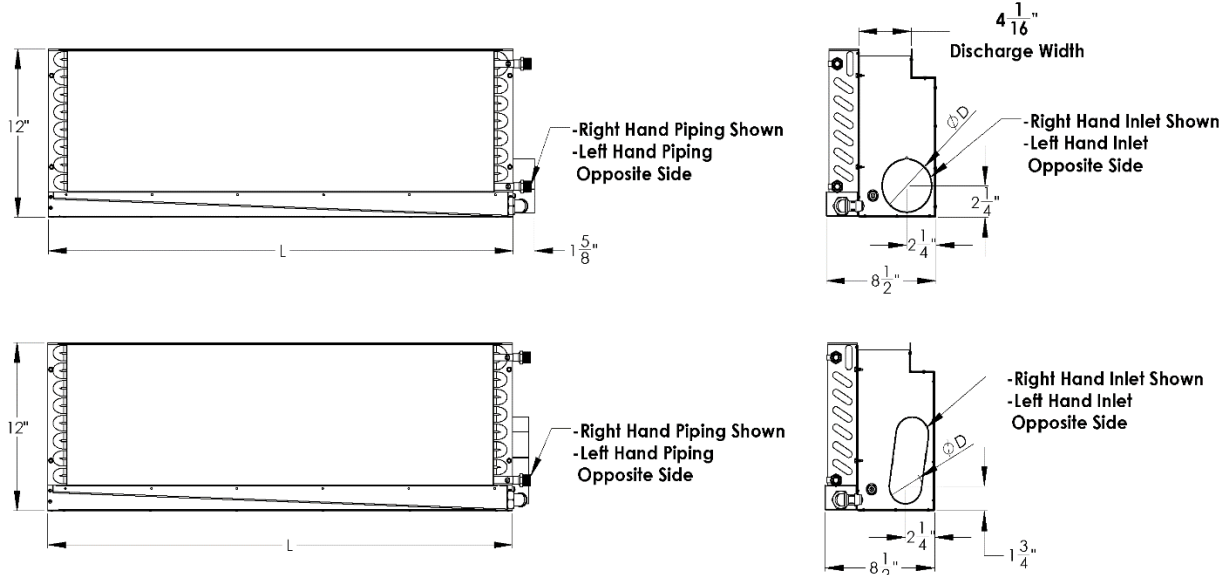

Back Inlet and Fixed Bracket Mounting Locations

Beam Length	L (in)	A (in)
2'	24	23 1/4
3'	36	35 1/4
4'	48	47 1/4
5'	60	59 1/4
6'	72	71 1/4

Inlet	D (in)
3"	2 3/4
4"	3 3/4
5" Oval	2 1/2 x 6 1/4

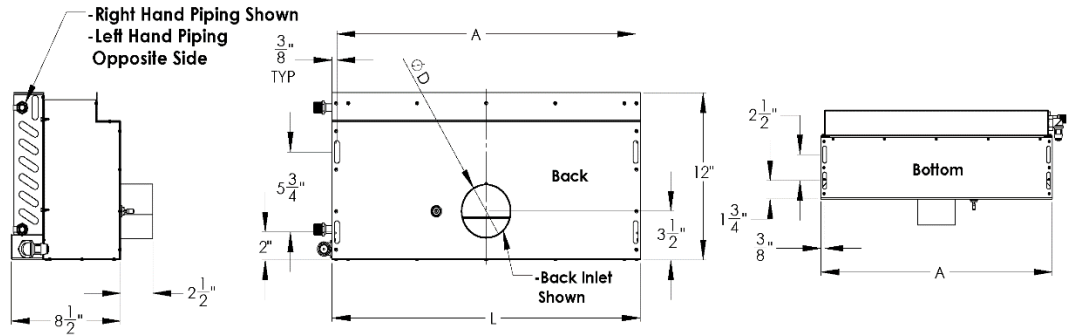

Piping Configurations

-2 Pipe Coil Connections
-Right Hand Piping Shown
-Left Hand Opposite Side

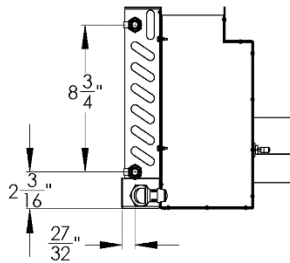

-4 Pipe Coil Connections
-Right Hand Piping Shown
-Left Hand Opposite Side

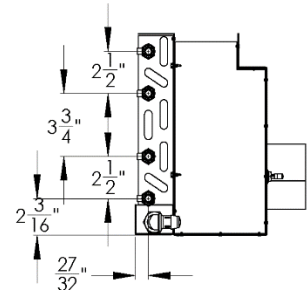

CS-ID-17 DIMENSIONAL DATA

Side Inlet Locations

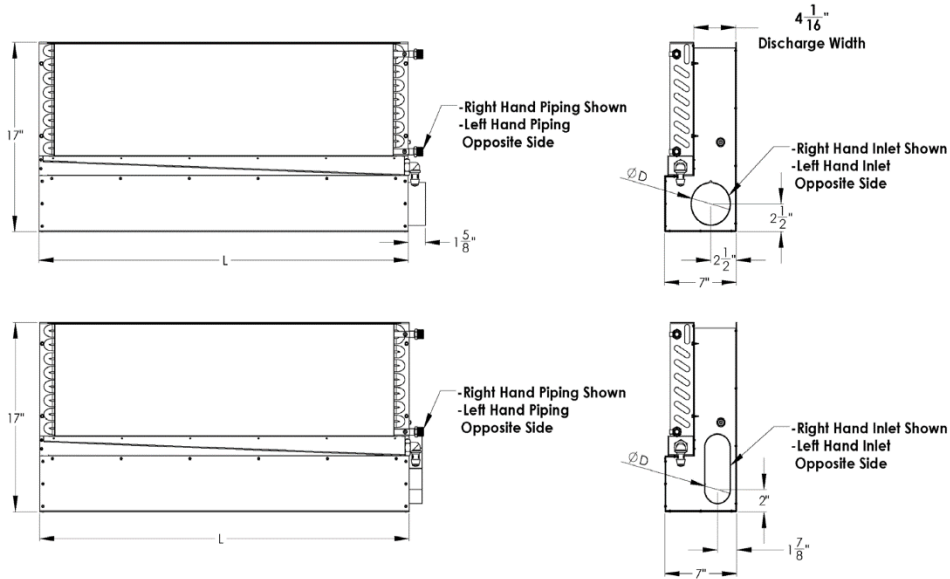

Back Inlet and Fixed Bracket Mounting Locations

Beam Length	L (in)	A (in)
2'	24	23 1/4
3'	36	35 1/4
4'	48	47 1/4
5'	60	59 1/4
6'	72	71 1/4

Inlet	D (in)
3"	2 3/4
4"	3 3/4
5" Oval	2 1/2 x 6 1/4

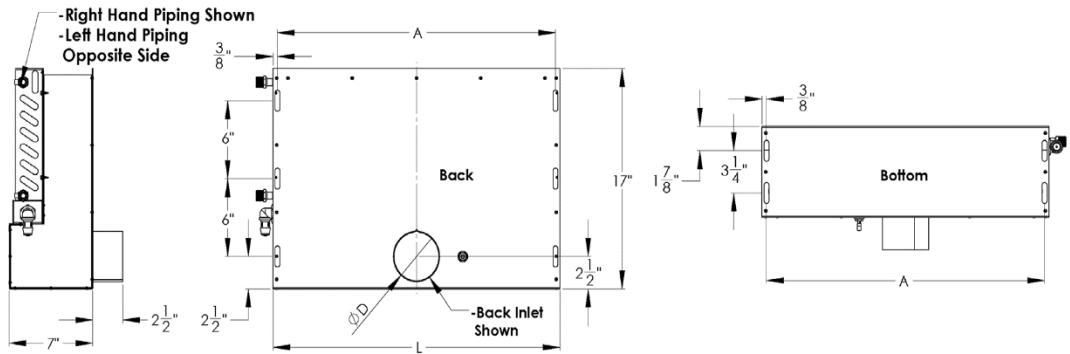

Piping Configurations

-2 Pipe Coil Connections
-Right Hand Piping Shown
-Left Hand Opposite Side

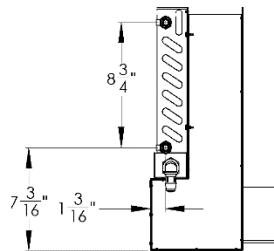

-4 Pipe Coil Connections
-Right Hand Piping Shown
-Left Hand Opposite Side

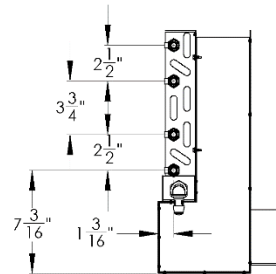

CS-ID STANDARD SPEC FEATURES

- Vertical upward air distribution
- 8.5" or 7" widths
- 12" or 17" heights
- 2' – 6' lengths, 1' increments
- Left hand or right hand coil connections
- Side, front, back, and top air inlet locations
- AHRI Standard 410 certified hydronic coil
- 2-pipe and 4-pipe coil configurations
- ½" MNPT water coil connections
- Coil drain valves
- Condensate drip trays with a capped ½" drain connection
- Optional factory mounted condensate float switch
- Four types of induction ratio nozzles
- Commissioning port for balancing
- Fixed slotted mounting locations
- 20GA Galv plenum construction sealed for protection against air leakage

OPTIONS AND ACCESSORIES

- ⅛" or ½" thick Armacell external insulation
- ½" sweet coil connections
- 12-inch, 18-inch, or 24-inch stainless steel braided hoses

CS-ID-12 NOMENCLATURE

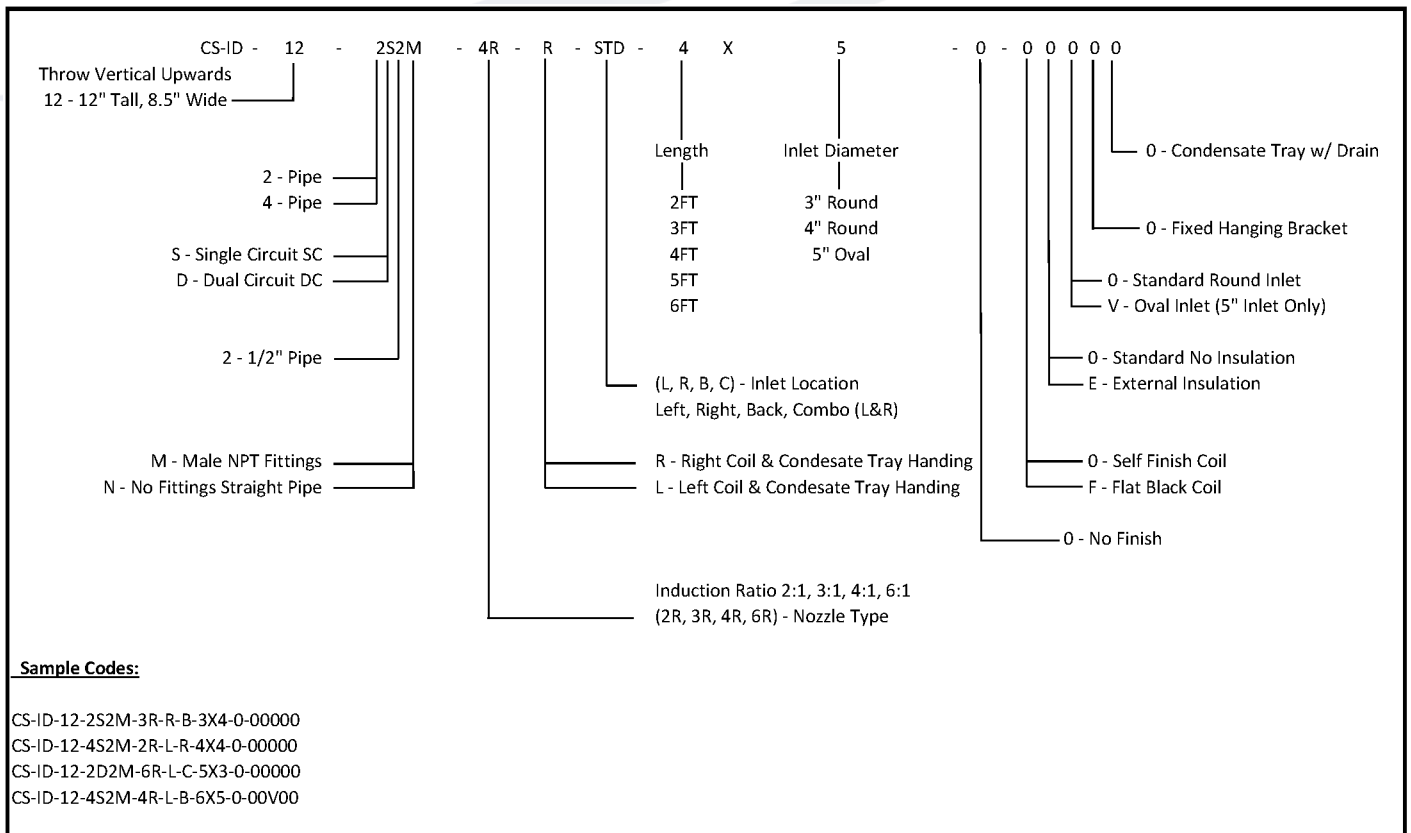

CS-ID-17 NOMENCLATURE

